

REVISIONS		
REV.	DESCRIPTION	DATE
A	INITIAL RELEASE	03/07/07
B	CHANGE DESCRIPTION OF ROLLERS FROM DRIVE SEAM TO DOUBLE SEAM	3/21/2007

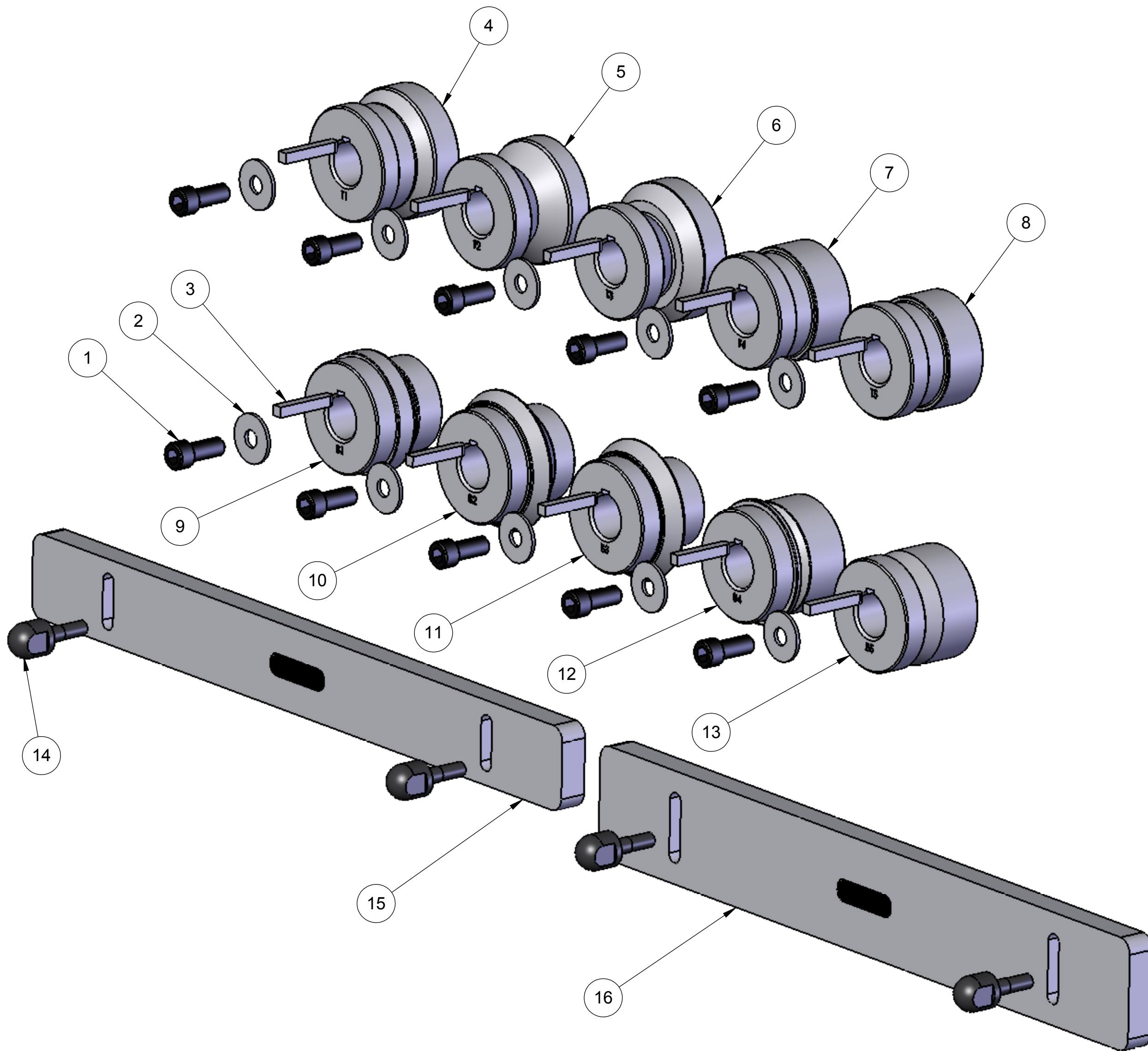

INSTALLATION INSTRUCTIONS:

1. INSTALL ROLLERS, MARKED "T1" & "B1", ONTO THE SHAFTS AT THE LEFT SIDE, OR FEED SIDE OF MACHINE, PLACING "T1" ON THE UPPER SHAFT AND "B1" ON THE LOWER SHAFT.
2. REPEAT THE ABOVE PROCEDURE FOR THE REMAINING ROLLERS IN NUMERIC ORDER.
3. **ALL ROLLERS MARKED "T" SHOULD BE ON THE TOP SHAFTS AND ROLLERS MARKED "B" SHOULD BE ON THE BOTTOM SHAFTS.**
4. **ALL ROLLER MARKINGS MUST FACE OUTWARD, OR TOWARDS THE OPERATOR.**
5. MOUNT ENTRANCE GUIDE BAR (ITEM 15) ON THE STARTING SIDE OF THE MACHINE AT 1-1/8" OFF OF THE EDGE OF THE ROLLERS.
6. THE EXIT GUIDE BAR (ITEM 16) ON THE FINISHING SIDE SHOULD BE FLUSH AGAINST THE METAL AS IT EMERGES FROM THE ROLLERS.

RAMS-2012 20 GA HYPERSPEED PITTSBURGH MACHINE

ITEM NO.	PART NUMBER	DESCRIPTION	QTY.
1	HW-1000	SHCS, 5/16-18 X 3/4, BLACK	10
2	HW-1010	WASHER, FLAT, 5/16	10
3	HW-1040	KEY, 3/16 X 3/16 X 1 3/16	10
4	DS-T1	ROLLER, T1, DOUBLE SEAM	1
5	DS-T2	ROLLER, T2, DOUBLE SEAM	1
6	DS-T3	ROLLER, T3, DOUBLE SEAM	1
7	DS-T4	ROLLER, T4, DOUBLE SEAM	1
8	DS-T5	ROLLER, T5, DOUBLE SEAM	1
9	DS-B1	ROLLER, B1, DOUBLE SEAM	1
10	DS-B2	ROLLER, B2, DOUBLE SEAM	1
11	DS-B3	ROLLER, B3, DOUBLE SEAM	1
12	DS-B4	ROLLER, B4, DOUBLE SEAM	1
13	DS-B5	ROLLER, B5, DOUBLE SEAM	1
14	2054	ADJUSTING BOLT: 1/4-20 THREAD	4
15	HY-1055	GUIDE BAR, 14"	1
16	2053-2	AUXILLARY GUIDE BAR, 14"	1

DIMENSIONS ARE IN INCHES
 TOLERANCES:
 FRACTIONAL ± 1/16
 ANGULAR: MACH ± BEND ±
 TWO PLACE DECIMAL ±.01
 THREE PLACE DECIMAL ±.005

	NAME	DATE
DRAWN	RAF	1/16/2007
CHECKED		
ENG APPR.		
MFG APPR.		
Q.A.		

HORIZON SYSTEMS MACHINING
 9121 58TH PLACE
 KENOSHA, WI 53144
 PH: 262-605-1122
 FAX: 262-605-1198

THE INFORMATION CONTAINED IN THIS DRAWING IS THE SOLE PROPERTY OF HORIZON SYSTEMS MACHINING. ANY REPRODUCTION IN PART OR AS A WHOLE WITHOUT THE WRITTEN PERMISSION OF HORIZON SYSTEMS MACHINING IS PROHIBITED.

MATERIAL	SEE BOM
FINISH	N/A
DO NOT SCALE DRAWING	

TITLE:	HYPERSPEED-AUX-A		
SIZE	DWG. NO.	REV	
C	HYPERSPEED-AUX-A	B	
SCALE:	1:1.5	SHEET 1 OF 1	