

REVISIONS				
ZONE	REV.	DESCRIPTION	DATE	APPROVED
	A	INITIAL RELEASE	11/11/08	SSL

ROLLER STORAGE TRAY

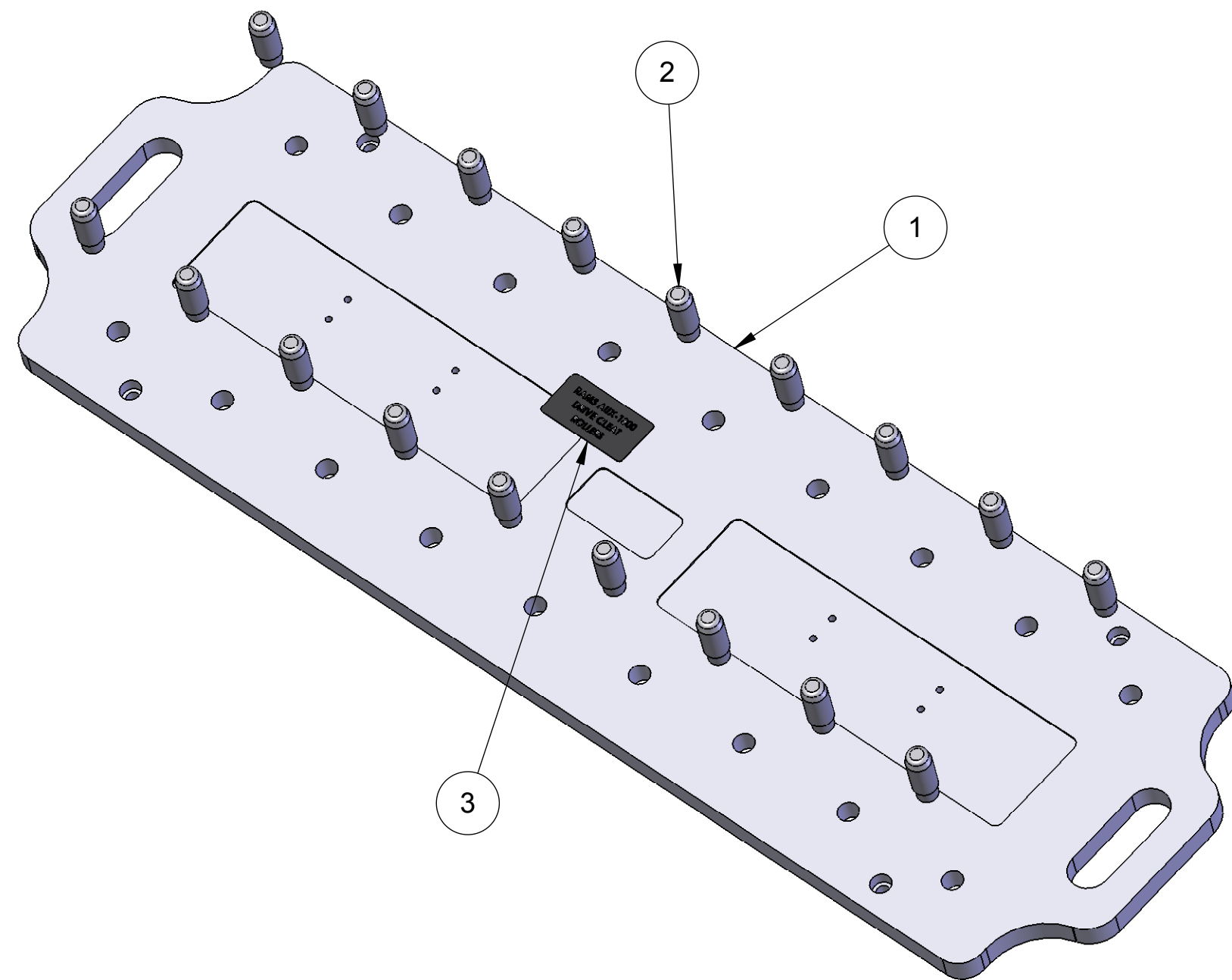
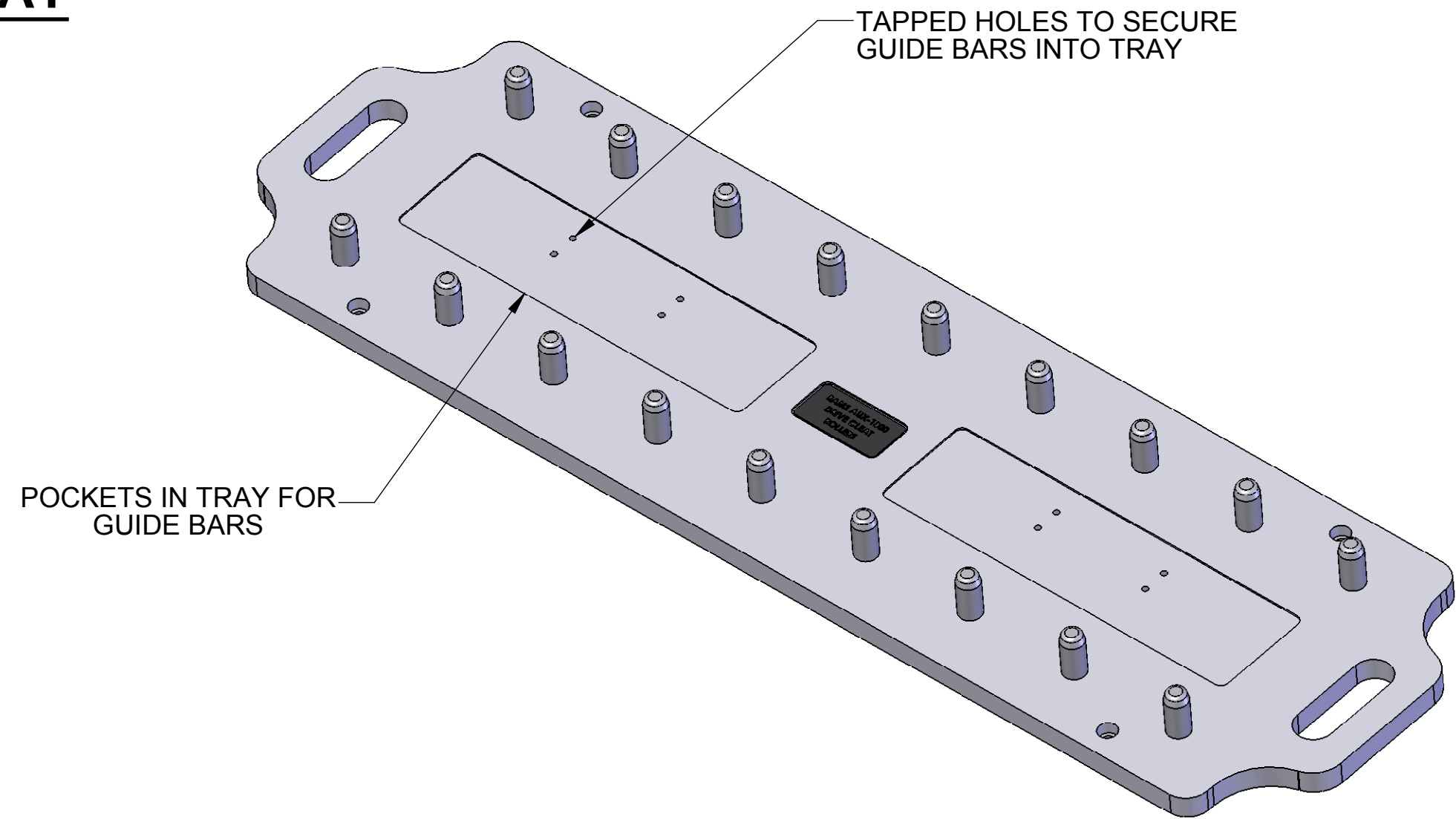

RAMS 2014 - AUXILIARY MACHINE

TRAY PART NUMBER	DESCRIPTION	LABEL PART NUMBER
RAMS AUX-2300-DC	DRIVE CLEAT ROLLER TRAY	AX-1850
RAMS AUX-2300-61	6 in 1 TAP-IN ROLLER TRAY	AX-1450
RAMS AUX-2300-MB	MALE BUTTON LOCK ROLLER TRAY	AX-2150
RAMS AUX-2300-FB	FEMALE BUTTON LOCK ROLLER TRAY	AX-2250
RAMS AUX-2300-DS	ACME DOUBLE SEAM ROLLER TRAY	AX-1650

ITEM NO.	PART NUMBER	DESCRIPTION	QTY.
1	AX-2301	BASE, ROLLER TRAY	1
2	AX-2302	SHAFT, STORAGE TRAY	18
3	SEE TABLE ABOVE	LABEL	1

DIMENSIONS ARE IN INCHES TOLERANCES: FRACTIONAL $\pm 1/16$ ANGULAR: MACH \pm BEND \pm TWO PLACE DECIMAL $\pm .01$ THREE PLACE DECIMAL $\pm .005$	NAME	DATE	HORIZON SYSTEMS MACHINING 9121 58TH PLACE KENOSHA, WI 53144 PH: 262-605-1122 FAX: 262-605-1198	
	DRAWN	SSL		10/21/08
	CHECKED			
	ENG APPR.			
	MFG APPR.			
	Q.A.			
THE INFORMATION CONTAINED IN THIS DRAWING IS THE SOLE PROPERTY OF HORIZON SYSTEMS MACHINING. ANY REPRODUCTION IN PART OR AS A WHOLE WITHOUT THE WRITTEN PERMISSION OF HORIZON SYSTEMS MACHINING IS PROHIBITED.	MATERIAL	TITLE: ROLLER TRAY		
	FINISH	SEE BOM	SIZE DWG. NO. REV	
		N/A	C RAMS AUX-2300-__ A	
DO NOT SCALE DRAWING		SCALE: 1:4	SHEET 1 OF 1	