

REVISIONS			
REV.	DESCRIPTION	DATE	APPROVED

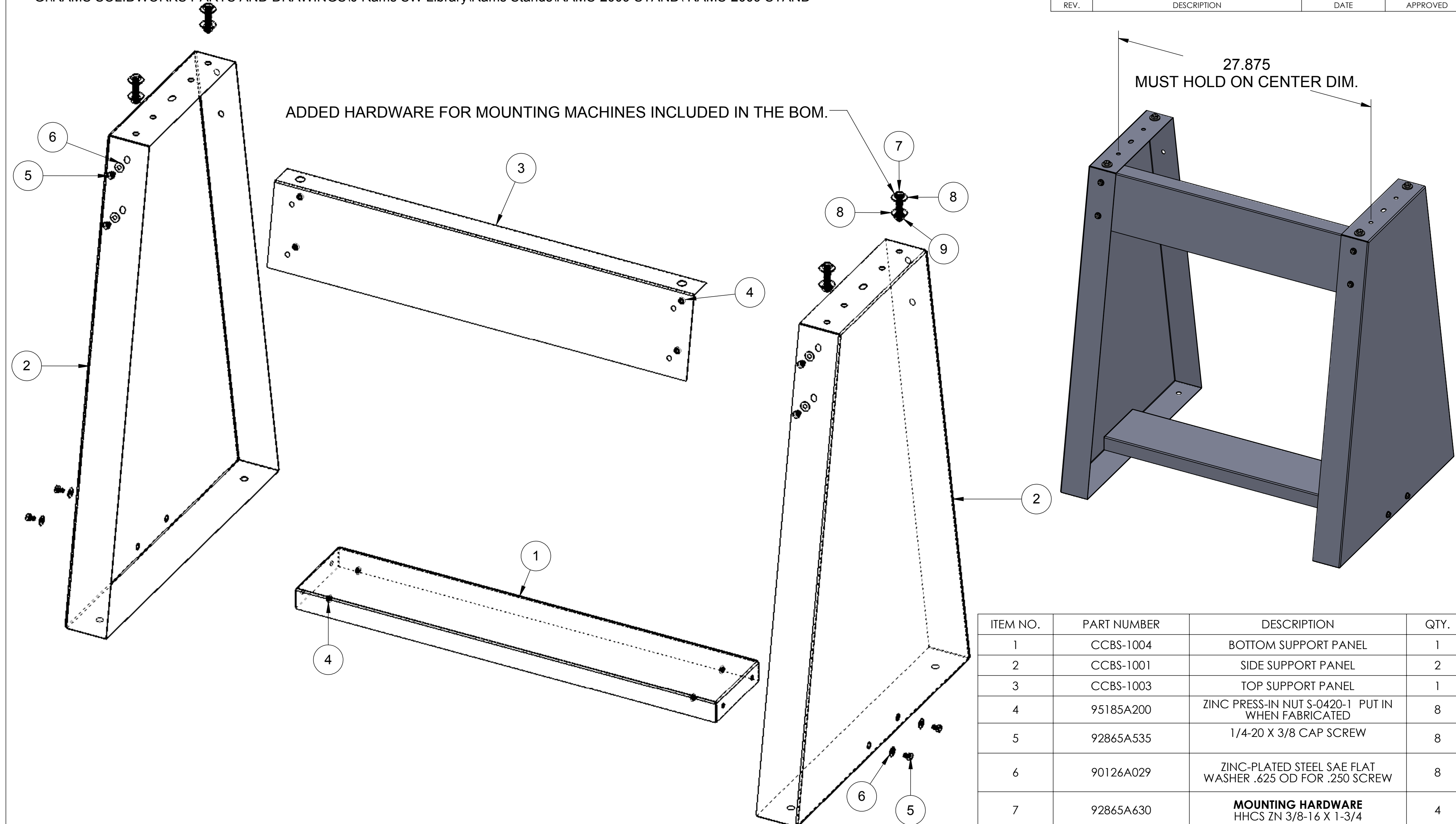

ADDED HARDWARE FOR MOUNTING MACHINES INCLUDED IN THE BOM.

27.875  
MUST HOLD ON CENTER DIM.

**NOTES:  
MUST HOLD ON CENTER DIM. WHEN ASSEMBLE**

ITEM NO.	PART NUMBER	DESCRIPTION	QTY.
1	CCBS-1004	BOTTOM SUPPORT PANEL	1
2	CCBS-1001	SIDE SUPPORT PANEL	2
3	CCBS-1003	TOP SUPPORT PANEL	1
4	95185A200	ZINC PRESS-IN NUT S-0420-1 PUT IN WHEN FABRICATED	8
5	92865A535	1/4-20 X 3/8 CAP SCREW	8
6	90126A029	ZINC-PLATED STEEL SAE FLAT WASHER .625 OD FOR .250 SCREW	8
7	92865A630	<b>MOUNTING HARDWARE</b> HHCS ZN 3/8-16 X 1-3/4	4
8	90108A417	<b>MOUNTING HARDWARE</b> ZINC-PLATED STEEL USS FLAT WASHER 1.00 OD FOR .375 SCREW	8
9	95462A031	<b>MOUNTING HARDWARE</b> 3/8-16 X .328 THK. GRADE 5 STEEL HEX NUT	4

**RAMS-2009 CLEAT/CHEEK BENDER STAND**

DIMENSIONS ARE IN INCHES TOLERANCES: FRACTIONAL ± 1/16 ANGULAR: MACH ± BEND ± TWO PLACE DECIMAL ±.01 THREE PLACE DECIMAL ±.005	NAME: JK DATE: 5/29/2019	<b>HORIZON SYSTEMS MACHINING</b> 9121 58TH PLACE KENOSHA, WI 53144 PH: 262-605-1122 FAX: 262-605-1198	
	MATERIAL:		TITLE:
	FINISH: SEE NOTES		SIZE DWG. NO. C RAMS-2009 STAND
	DO NOT SCALE DRAWING		SCALE: 1:8 SHEET 1 OF 1

THE INFORMATION CONTAINED IN THIS DRAWING IS THE SOLE PROPERTY OF HORIZON SYSTEMS MACHINING. ANY REPRODUCTION IN PART OR AS A WHOLE WITHOUT THE WRITTEN PERMISSION OF HORIZON SYSTEMS MACHINING IS PROHIBITED.