

REVISIONS				
ZONE	REV.	DESCRIPTION	DATE	APPROVED

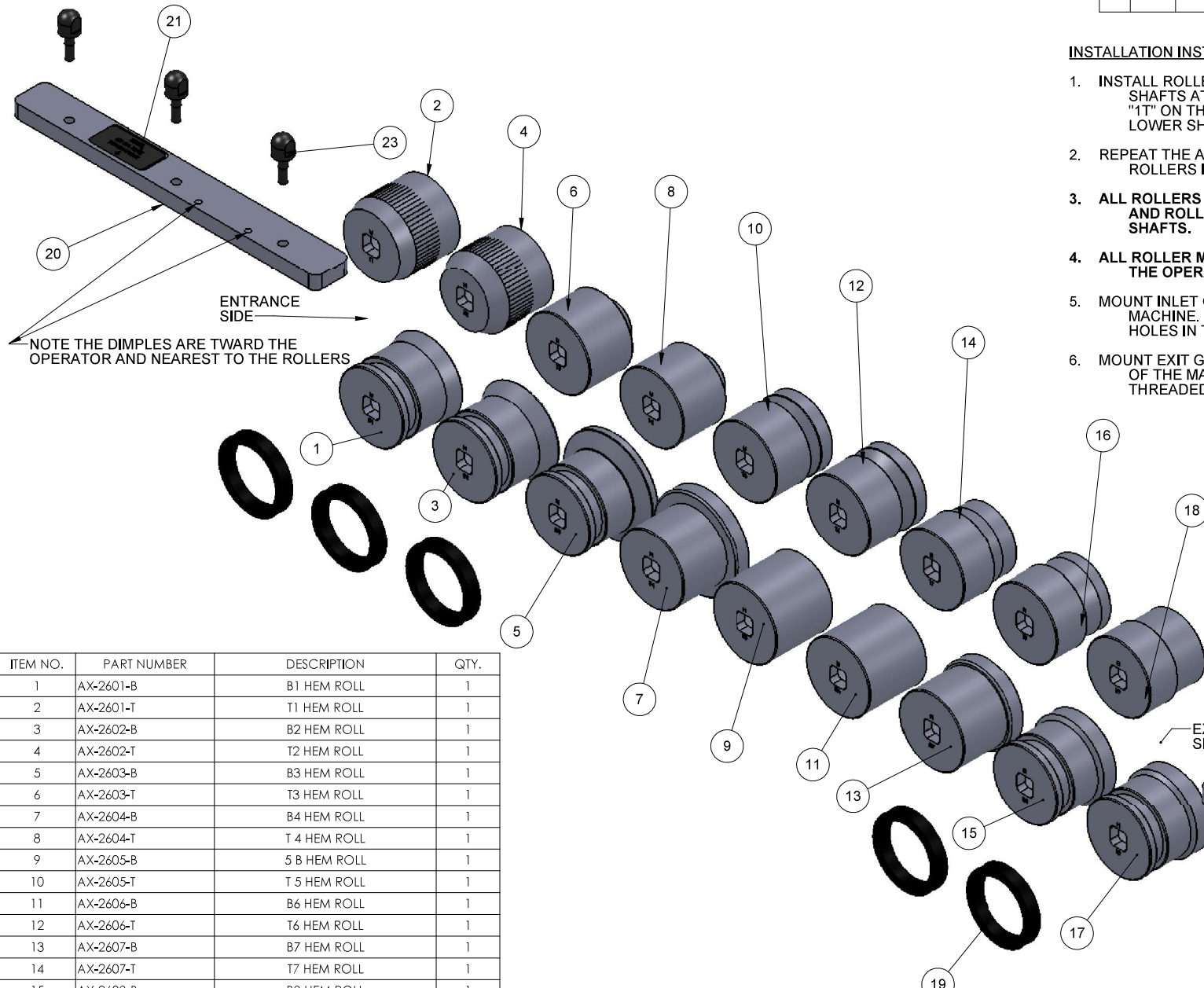

**INSTALLATION INSTRUCTIONS:**

1. INSTALL ROLLERS, MARKED "1T" & "1B", ONTO THE SHAFTS AT THE INLET SIDE OF MACHINE, PLACING "1T" ON THE UPPER SHAFT AND "1B" ON THE LOWER SHAFT.
2. REPEAT THE ABOVE PROCEDURE FOR THE REMAINING ROLLERS IN NUMERIC ORDER.
3. ALL ROLLERS MARKED "T" SHOULD BE ON THE TOP SHAFTS AND ROLLERS MARKED "B" SHOULD BE ON THE BOTTOM SHAFTS.
4. ALL ROLLER MARKINGS **MUST** FACE OUTWARD, OR TOWARDS THE OPERATOR.
5. MOUNT INLET GUIDE BAR (ITEM 20) ON THE INLET SIDE OF THE MACHINE. GUIDE BAR TO BE BOLTED INTO THREADED HOLES IN TABLETOP OF MACHINE.
6. MOUNT EXIT GUIDE BAR (ITEM 22) ON THE EXIT SIDE OF THE MACHINE. GUIDE BAR TO BE BOLTED INTO THREADED HOLES IN TABLETOP OF MACHINE.

ITEM NO.	PART NUMBER	DESCRIPTION	QTY.
1	AX-2601-B	B1 HEM ROLL	1
2	AX-2601-T	T1 HEM ROLL	1
3	AX-2602-B	B2 HEM ROLL	1
4	AX-2602-T	T2 HEM ROLL	1
5	AX-2603-B	B3 HEM ROLL	1
6	AX-2603-T	T3 HEM ROLL	1
7	AX-2604-B	B4 HEM ROLL	1
8	AX-2604-T	T 4 HEM ROLL	1
9	AX-2605-B	5 B HEM ROLL	1
10	AX-2605-T	T 5 HEM ROLL	1
11	AX-2606-B	B6 HEM ROLL	1
12	AX-2606-T	T6 HEM ROLL	1
13	AX-2607-B	B7 HEM ROLL	1
14	AX-2607-T	T7 HEM ROLL	1
15	AX-2608-B	B8 HEM ROLL	1
16	AX-2608-T	T8 HEM ROLL	1
17	AX-2609-B	B9 HEM ROLL	1
18	AX-2609-T	T9 HEM ROLL	1
19	AX-2699	ROLLER SLEEVE	5
20	AX-2611	ENTRANCE GUIDE BAR HEM	1
21	AX-2611-1	LABEL, GUIDE BAR, HEM 20GA MAX	2
22	AX-2612	EXIT GUID BAR HEM	1
23	2054	ADJUSTING BOLT:1/4-20 THREAD	6

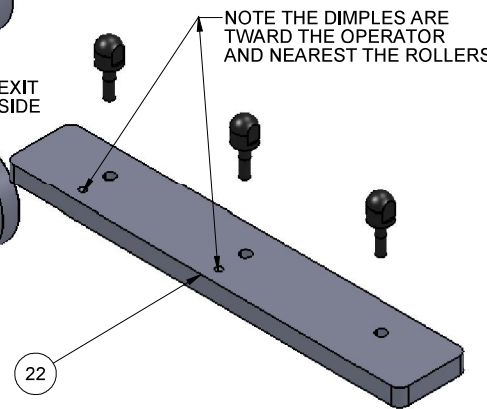

**DIMENSIONS ARE IN INCHES**  
**TOLERANCES:**  
 FRACTIONAL ± 1/16  
 ANGULAR: MACH ± BEND ±  
 TWO PLACE DECIMAL ±.01  
 THREE PLACE DECIMAL ±.005

DRAWN	NAME	DATE	<b>HORIZON SYSTEMS MACHINING</b>	
CHECKED	SJB	10/19/2014	9121 58TH PLACE KENOSHA, WI 53144 PH: 262-605-1122 FAX: 262-605-1198	
ENG APPR.			TITLE:	
MFG APPR.			MATERIAL: <b>SEE BOM</b>	
G.A.			SIZE: <b>C</b>	DWG. NO.: <b>AX2600</b>
DO NOT SCALE DRAWING			SCALE: 1:8	SHEET 1 OF 1

THE INFORMATION CONTAINED IN THIS DRAWING IS THE SOLE PROPERTY OF HORIZON SYSTEMS MACHINING. ANY REPRODUCTION IN PART OR AS A WHOLE WITHOUT THE WRITTEN PERMISSION OF HORIZON SYSTEMS MACHINING IS PROHIBITED.