

REVISIONS		
REV.	DESCRIPTION	DATE
A	INITIAL RELEASE	4/27/11

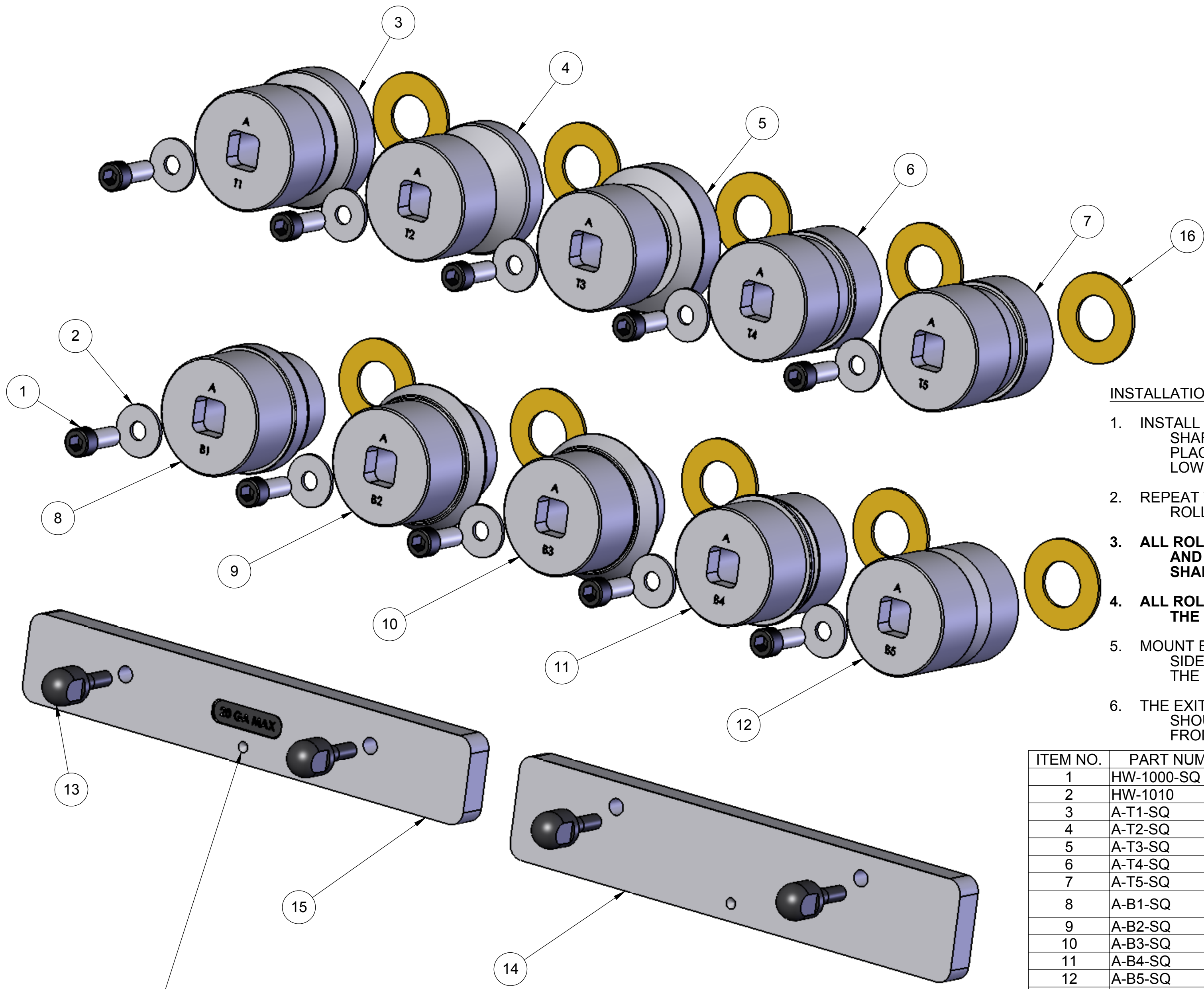

**INSTALLATION INSTRUCTIONS:**

1. INSTALL ROLLERS, MARKED "T1" & "B1", ONTO THE SHAFTS AT THE LEFT SIDE, OR FEED SIDE OF MACHINE, PLACING "T1" ON THE UPPER SHAFT AND "B1" ON THE LOWER SHAFT.
2. REPEAT THE ABOVE PROCEDURE FOR THE REMAINING ROLLERS IN NUMERIC ORDER.
3. **ALL ROLLERS MARKED "T" SHOULD BE ON THE TOP SHAFTS AND ROLLERS MARKED "B" SHOULD BE ON THE BOTTOM SHAFTS.**
4. **ALL ROLLER MARKINGS MUST FACE OUTWARD, OR TOWARDS THE OPERATOR.**
5. MOUNT ENTRANCE GUIDE BAR (ITEM 15) ON THE STARTING SIDE OF THE MACHINE AT 1-1/8" OFF OF THE EDGE OF THE ROLLERS.
6. THE EXIT GUIDE BAR (ITEM 16) ON THE FINISHING SIDE SHOULD BE FLUSH AGAINST THE METAL AS IT EMERGES FROM THE ROLLERS.

LOCATING SPOTS INDICATE SIDE OF GUIDE BAR TO FACE OPERATOR

ITEM NO.	PART NUMBER	DESCRIPTION	QTY.
1	HW-1000-SQ	SHCS, 5/16-18 X 1/2, BLACK	10
2	HW-1010	WASHER, FLAT, 5/16	10
3	A-T1-SQ	ROLLER, T1, DOUBLE SEAM	1
4	A-T2-SQ	ROLLER, T2, DOUBLE SEAM	1
5	A-T3-SQ	ROLLER, T3, DOUBLE SEAM	1
6	A-T4-SQ	ROLLER, T4, DOUBLE SEAM	1
7	A-T5-SQ	ROLLER, T5, DOUBLE SEAM	1
8	A-B1-SQ	ROLLER, B1, DOUBLE SEAM, SQUARE DRIVE	1
9	A-B2-SQ	ROLLER, B2, DOUBLE SEAM	1
10	A-B3-SQ	ROLLER, B3, DOUBLE SEAM	1
11	A-B4-SQ	ROLLER, B4, DOUBLE SEAM	1
12	A-B5-SQ	ROLLER, B5, DOUBLE SEAM	1
13	2054	ADJUSTING BOLT: 1/4-20 THREAD	4
14	2053-1	AUXILIARY GUIDE BAR	1
15	2053	GUIDE BAR, AUX-A	1
16	HW-SQ-1011	WASHER, FLAT BRASS	10

DIMENSIONS ARE IN INCHES  
TOLERANCES:  
FRACTIONAL ± 1/16  
ANGULAR: MACH ± BEND ±  
TWO PLACE DECIMAL ±.01  
THREE PLACE DECIMAL ±.005

DRAWN	CNC	DATE	4/27/11
CHECKED			
ENG APPR.			
MFG APPR.			
Q.A.			

**HORIZON SYSTEMS MACHINING**  
9121 58TH PLACE  
KENOSHA, WI 53144  
PH: 262-605-1122  
FAX: 262-605-1198

MATERIAL: SEE BOM  
FINISH: N/A  
DO NOT SCALE DRAWING

TITLE: RAMS-AUX-A-SQ  
SIZE: C  
DWG. NO.: RAMS-AUX-A-SQ  
REV: A  
SCALE: 1:1.25  
SHEET 1 OF 1